

LAP-2C

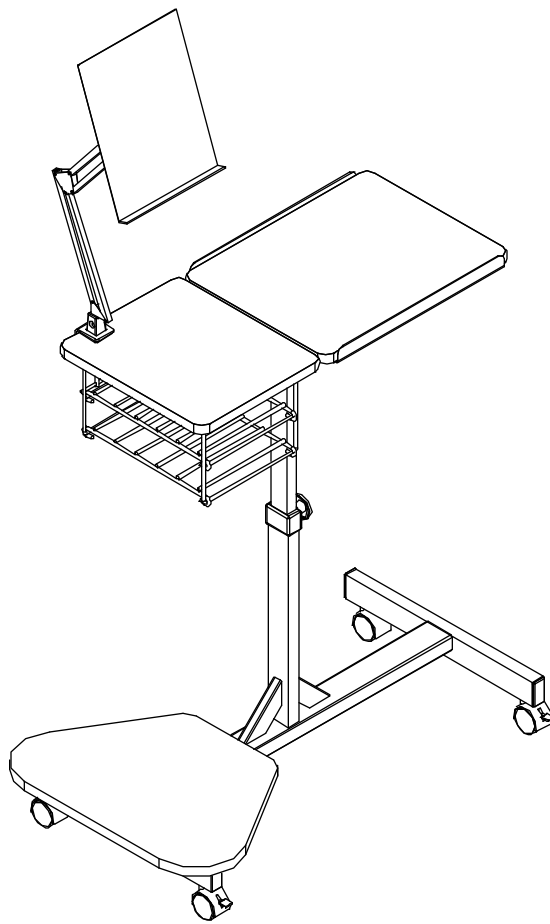









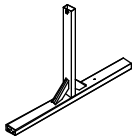

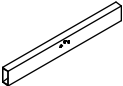





































Mobile Laptop Workstation



Assembly Instructions

LAP-2C

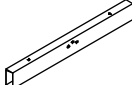
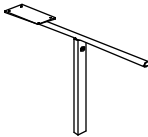
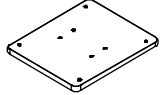
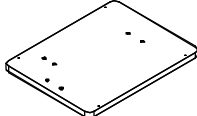
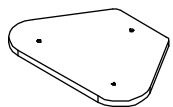
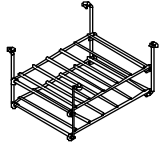
Mobile Laptop Workstation

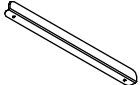
Part	Drawing	Description	Qty	Part	Drawing	Description	Qty																																																												
P-1		Lower Receiver	1 EA	P-12		Copyholder	1 EA																																																												
P-2		Right Foot	1 EA	<div style="text-align: center;"> <h3>Hardware List</h3> <table border="1"> <tbody> <tr> <td>A</td> <td></td> <td>9/16" Flat Head Screw</td> <td>11 EA</td> </tr> <tr> <td>A1</td> <td></td> <td>3/4" Flat Head Screw</td> <td>4 EA</td> </tr> <tr> <td>B</td> <td></td> <td>1-5/8" Flat Head Screw</td> <td>1 EA</td> </tr> <tr> <td>C</td> <td></td> <td>1-7/8" Flat Head Screw</td> <td>6 EA</td> </tr> <tr> <td>D</td> <td></td> <td>2-3/8" Flat Head Screw</td> <td>2 EA</td> </tr> <tr> <td>E</td> <td></td> <td>Flat Washer</td> <td>4 EA</td> </tr> <tr> <td>F</td> <td></td> <td>1/2" PH Wood Screw</td> <td>4 EA</td> </tr> <tr> <td>G1</td> <td></td> <td>Large Knob</td> <td>1 EA</td> </tr> <tr> <td>G2</td> <td></td> <td>Small Knob</td> <td>1 EA</td> </tr> <tr> <td>H</td> <td></td> <td>2" Locking Caster (for front)</td> <td>2 EA</td> </tr> <tr> <td>J</td> <td></td> <td>2" Caster (for Back)</td> <td>2 EA</td> </tr> <tr> <td>K</td> <td></td> <td>Allen Wrench</td> <td>1 EA</td> </tr> <tr> <td>L</td> <td></td> <td>Caster Wrench</td> <td>1 EA</td> </tr> <tr> <td>M</td> <td></td> <td>Plastic Cap</td> <td>1 EA</td> </tr> <tr> <td>N</td> <td></td> <td>Plastic Sleeve</td> <td>1 EA</td> </tr> </tbody> </table> <p>Tools required: Phillips Head Screw Driver</p> </div>				A		9/16" Flat Head Screw	11 EA	A1		3/4" Flat Head Screw	4 EA	B		1-5/8" Flat Head Screw	1 EA	C		1-7/8" Flat Head Screw	6 EA	D		2-3/8" Flat Head Screw	2 EA	E		Flat Washer	4 EA	F		1/2" PH Wood Screw	4 EA	G1		Large Knob	1 EA	G2		Small Knob	1 EA	H		2" Locking Caster (for front)	2 EA	J		2" Caster (for Back)	2 EA	K		Allen Wrench	1 EA	L		Caster Wrench	1 EA	M		Plastic Cap	1 EA	N		Plastic Sleeve	1 EA
A		9/16" Flat Head Screw	11 EA																																																																
A1		3/4" Flat Head Screw	4 EA																																																																
B		1-5/8" Flat Head Screw	1 EA																																																																
C		1-7/8" Flat Head Screw	6 EA																																																																
D		2-3/8" Flat Head Screw	2 EA																																																																
E		Flat Washer	4 EA																																																																
F		1/2" PH Wood Screw	4 EA																																																																
G1		Large Knob	1 EA																																																																
G2		Small Knob	1 EA																																																																
H		2" Locking Caster (for front)	2 EA																																																																
J		2" Caster (for Back)	2 EA																																																																
K		Allen Wrench	1 EA																																																																
L		Caster Wrench	1 EA																																																																
M		Plastic Cap	1 EA																																																																
N		Plastic Sleeve	1 EA																																																																
P-3		Left Foot	1 EA																																																																
P-4		Upper Insert	1 EA																																																																
P-5		Accessory Shelf	1 EA																																																																
P-6		Top Platform	1 EA																																																																
P-7		Lower Shelf	1 EA																																																																
P-8		Storage Rack	1 EA																																																																
P-9		C-Clamp	2 EA																																																																
P-10		Tilting Bracket	1 EA																																																																
P-11		Security Stop	2 EA																																																																

Do not use unless all screws are tight. At least every six months, check all screws to be sure they are tight. If parts are missing, broken, damaged, or worn, stop use of the product until repairs are made by your dealer using factory authorized parts.

LAP-2C

Assembly Diagram

READ THROUGH INSTRUCTIONS FROM BEGINNING TO END BEFORE STARTING TO ASSEMBLE UNIT.

1. Identify and Separate all the Parts and Hardware.
2. Attach Left Foot (P-3) on the end of Lower Receiver (P-1) with drill hole using 3 Flat Head screws (C). Attach Right Foot (P-2) on opposite end of Lower Receiver (P-1) using 3 Flat Head screws (C).
(Do not tighten screws all the way.)

3. Insert 2 Locking Casters (H) and 2 Casters (J) into Right Foot (P-2) and Left Foot (P-3) as shown in illustration # 1.

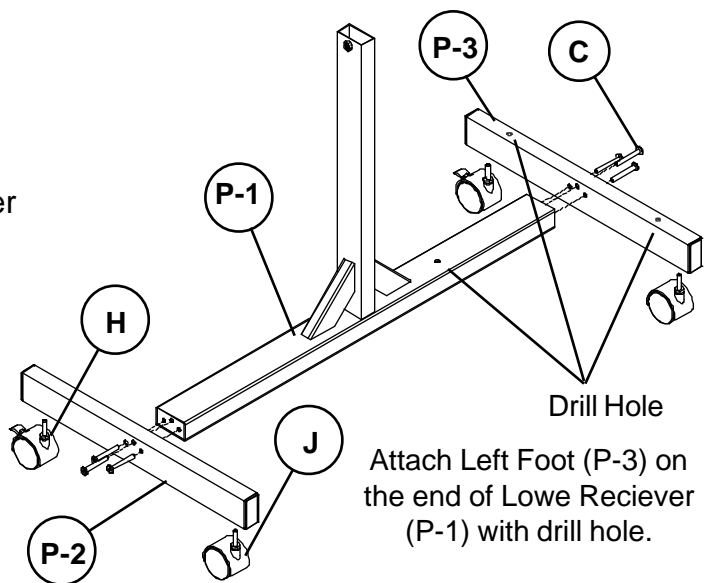

4. Attach Lower Printer Shelf (P-7) to the Lower Receiver (P-1), using 2 Flat Head screws (D) and 1 Flat Head screw (B) as shown in illustration # 2.

(Tighten all screws securely)

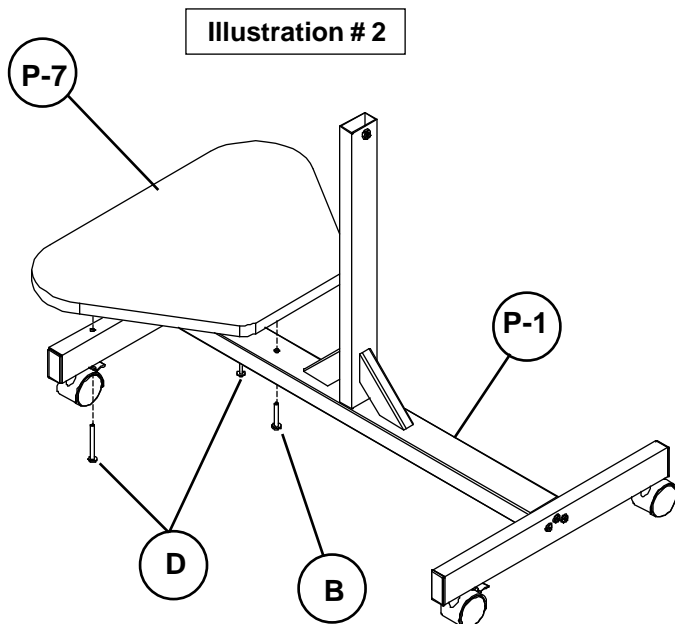

4. Attach Lower Printer Shelf (P-7) to the Lower Receiver (P-1), using 2 Flat Head screws (D) and 1 Flat Head screw (B) as shown in illustration # 2.

(Tighten all screws securely)

Illustration # 3

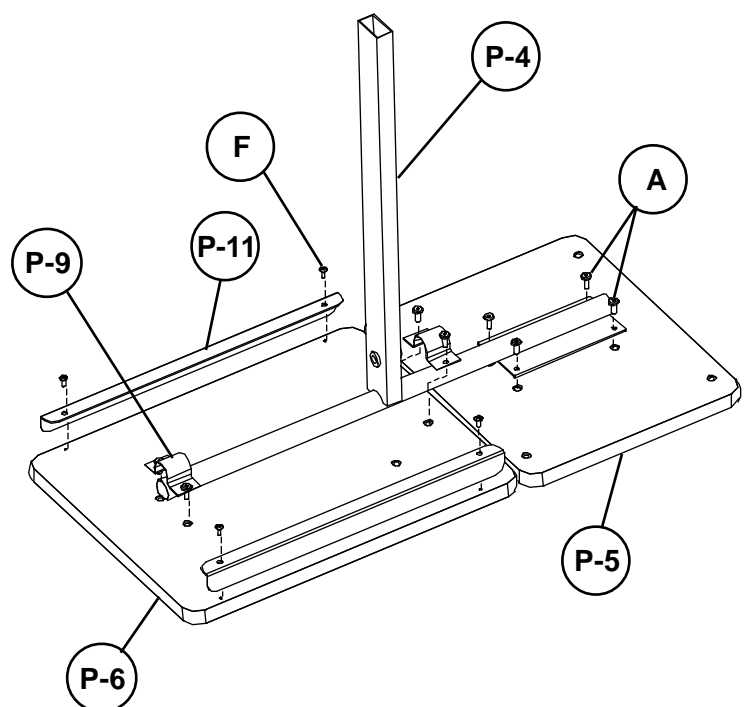

5. Align Top Platform (P-6) and Accessory Shelf (P-5) side by side as shown in illustration # 3.
6. Attach Upper Insert (P-4) to the Accessory Shelf (P-5) using 4 Flat Head Screws (A) as shown in illustration # 3.
7. Attach Top Platform (P-6) to Upper Insert (P-4) using 2 C-Clamps (P-9) and 4 Flat Head screws (A) as shown in illustration # 3.
8. Attach 2 Security Stops (P-11) using 4 Wood screws (F).

9. Attach Storage Rack (P-8) to the Accessory Shelf (P-5) using 4 Flat Head screws (A1) and 4 Flat Washers (E) as shown in illustration # 4.

10. Attach Tilting Bracket (P-10) to the Top Platform (P-6) using 2 Flat Head screws (A). Secure Tilting Bracket to Upper Insert (P-4) using the Large Knob (G1).

11. Please refer to the details on next page for assembling Plastic Cap (M), and the Plastic Sleeve (N).

Illustration # 4

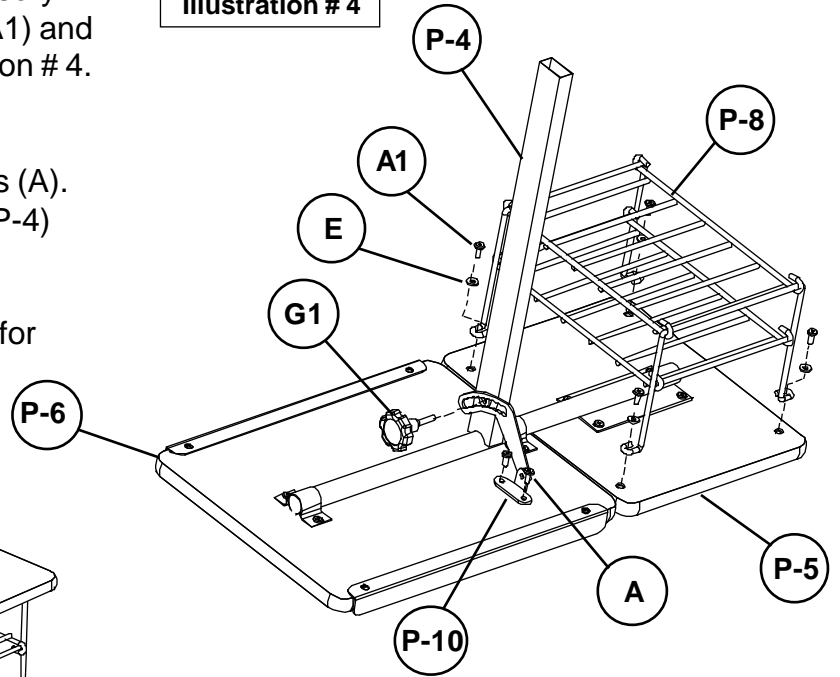
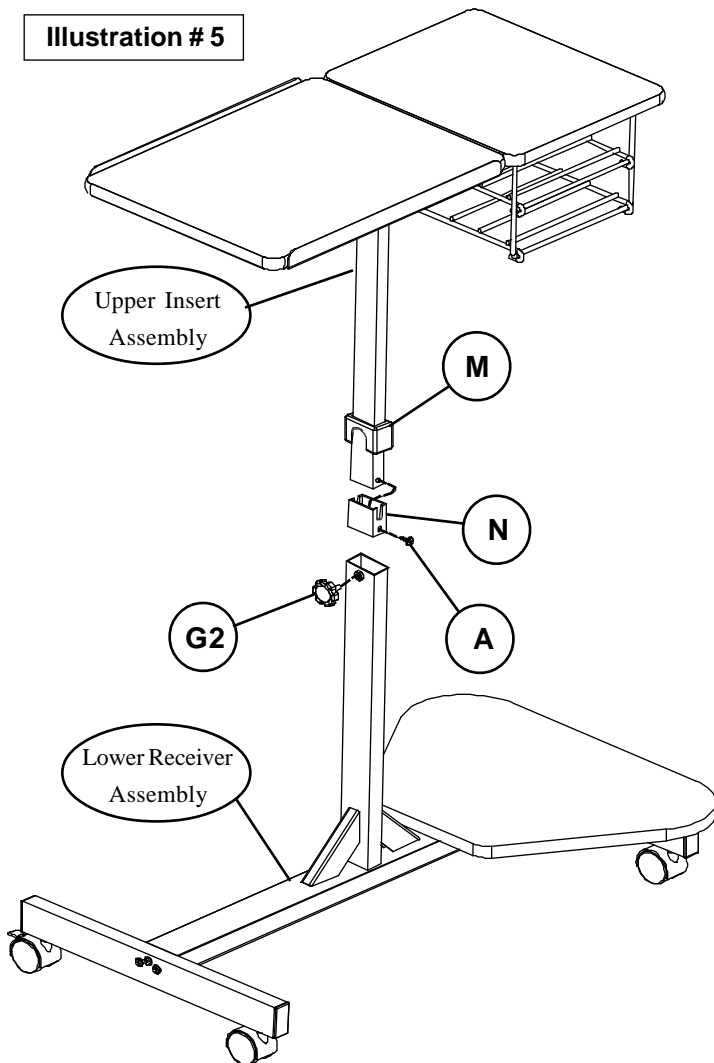
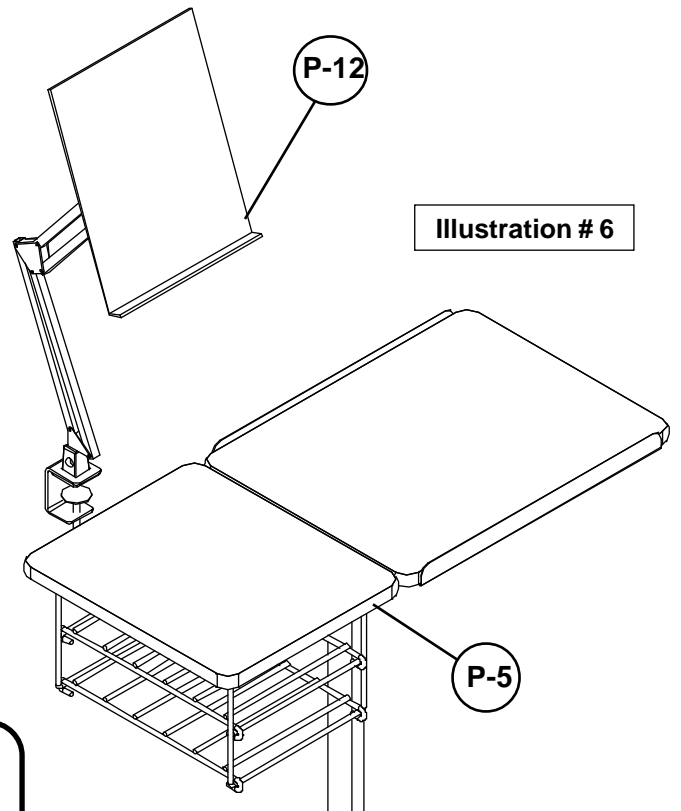

Illustration # 5



12. Insert Upper Insert Assembly into Lower Receiver Assembly, adjust to desired height and secure with the Small Knob (G2) as shown in illustration # 5.

Illustration # 6



13. Attach Copyholder (P-12) to Accessory Shelf (P-5) at desired location and secure with bottom clamp as shown in illustration # 6.

**Should you require assistance during assembly,
please call our Customer Service Department
Monday - Friday 7 a.m. - 4:30 p.m.
Pacific Standard Time**

**Toll-Free Customer Service
1-800-888-6024**

DETAILS OF ASSEMBLING PLASTIC CAP 'M' & SLEEVE 'N'

1. Slide Plastic Cap (M) [with Cutout on the same side as the tilting bracket on the Upper insert], then attach the Plastic sleeve (N) over the end of insert. Make sure that the hole on the Part N and the hole on the Upper insert tube line up, then attach it with a Flat Head screw (A).
2. Insert Upper insert into the Lower Receiver tube, and slide Part M down, so that it should be resting on top of the Lower Receiver Tube. Adjust to the desired height and secure with the Small Knob (G2) as shown in Illustration below.

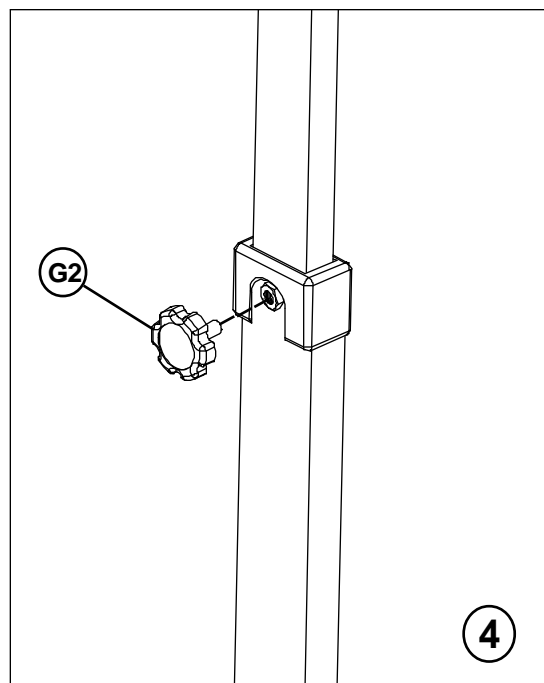
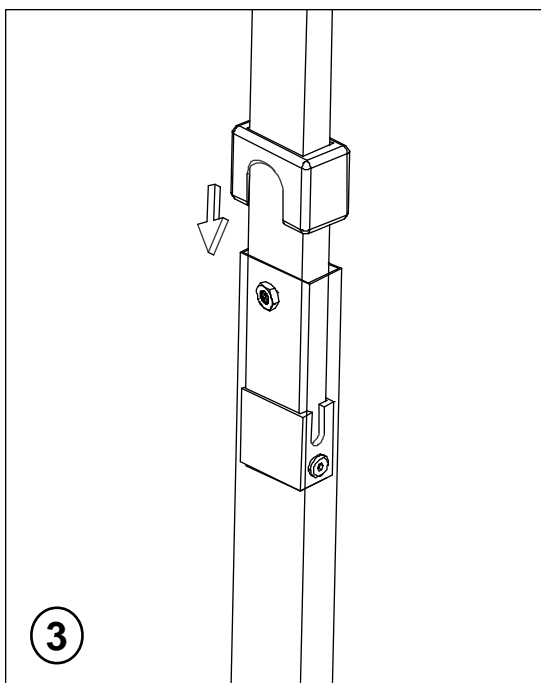
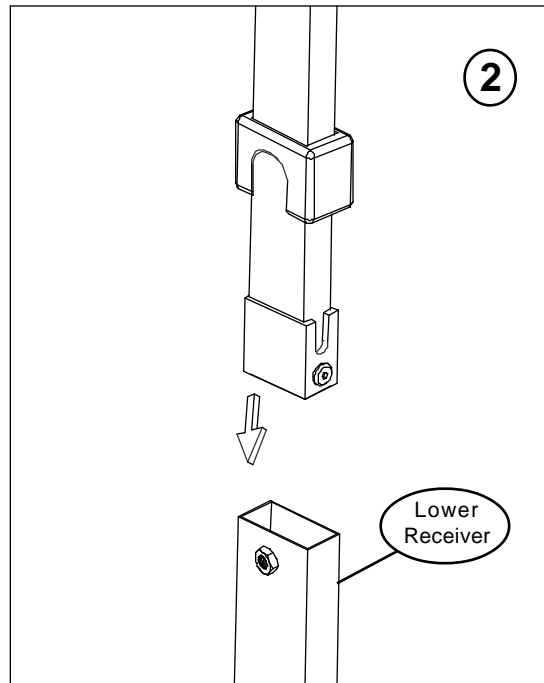
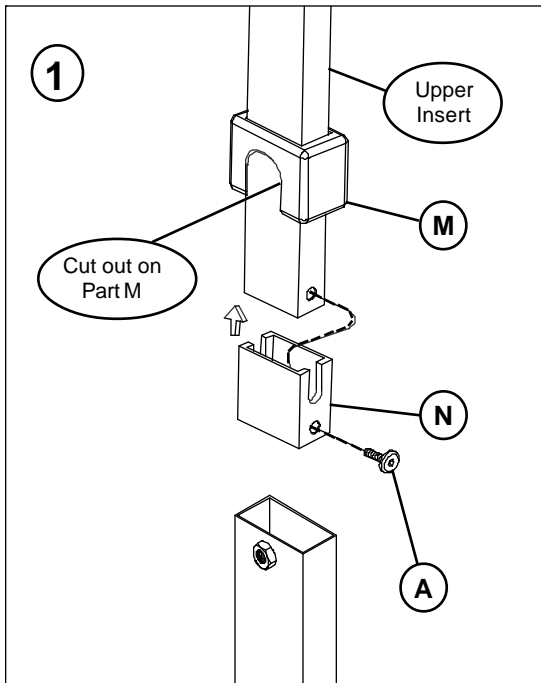

Lap-2C

Mobile Laptop Workstation

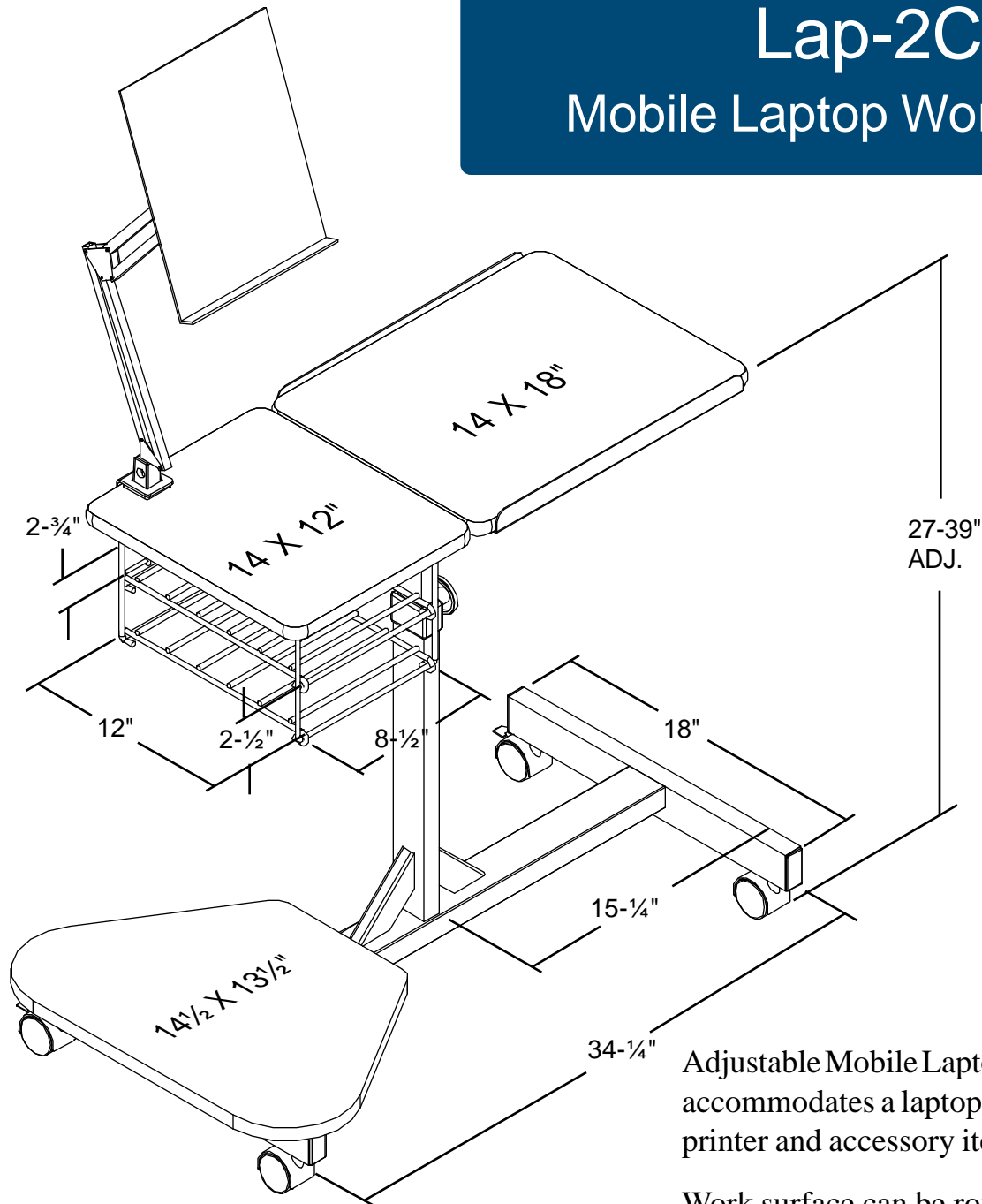

Adjustable Mobile Laptop Workstation accommodates a laptop computer, a small printer and accessory items for ease of access.

Work surface can be rotated up to 180° for right or left handed use.

Adjustable in height from 27" to 39" (w/casters) for easy chair, bedside or stand-up applications.

Copyholder (included in Lap-2C) can be positioned at any height or angle for user preference.

Includes 2 locking, and 2 non-locking casters.

Ships UPS.

Shipping Information

2.6 Cubic Feet
35 lbs.

