

# Installation Instructions

DISPLAY  
Direct Wall

## Component Checklist

### Direct Mount Configuration

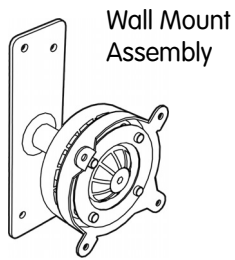

- Extension Clips (x4)
- 10mm Screws (x4)
- 12mm Screws (x4)
- 16mm Screws (x4)



### Quick Release Configuration



- Monitor Plate (x1)
- Key (x1)

## Bit Bag



M6 Coach  
Screws (x4)



S8 Nylon  
Anchor (x4)

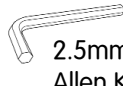

2.5mm Ball Joint Mechanism  
Allen Key (x1)



Washers (x4)



10mm  
Screws (x4)

## A Check Components

A.1. Check you have received all parts against the Component Checklist above.

## B Installing Wall Mount Assembly

B.1. For mounting to a timber stud wall - Using the Wall Mount Assembly's Bracket, mark the location of the 4 holes and drill using a 4mm drill bit. Secure the bracket to the wall using the M6 Coach Screws and Washers as shown in diagram B.1.1.

B.2. For mounting to a masonry wall - Using the Wall Mount Assembly's Bracket, mark the location of the 4 holes and drill using an 8mm masonry drill bit. Secure the bracket to the wall using the M6 Coach Screws, Washers and S8 Nylon Plugs as shown in diagram B.2.1.

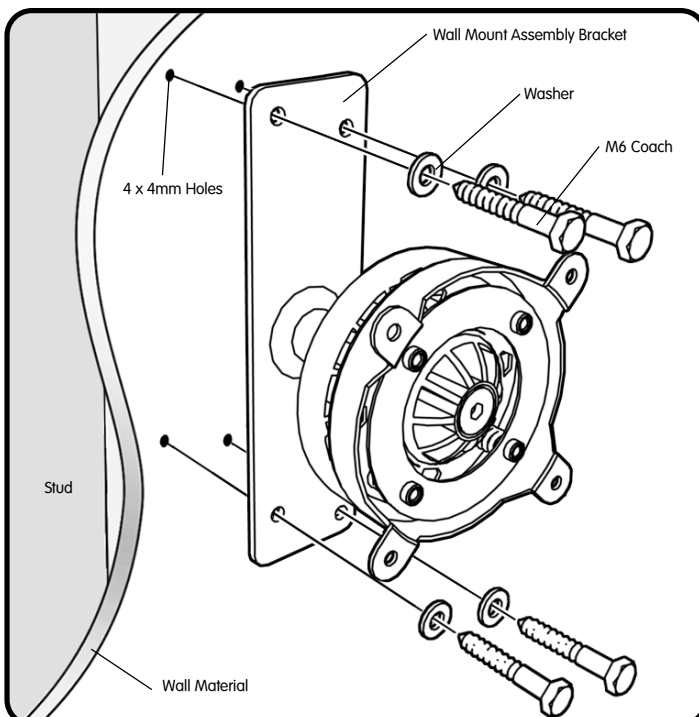

B.1.1.

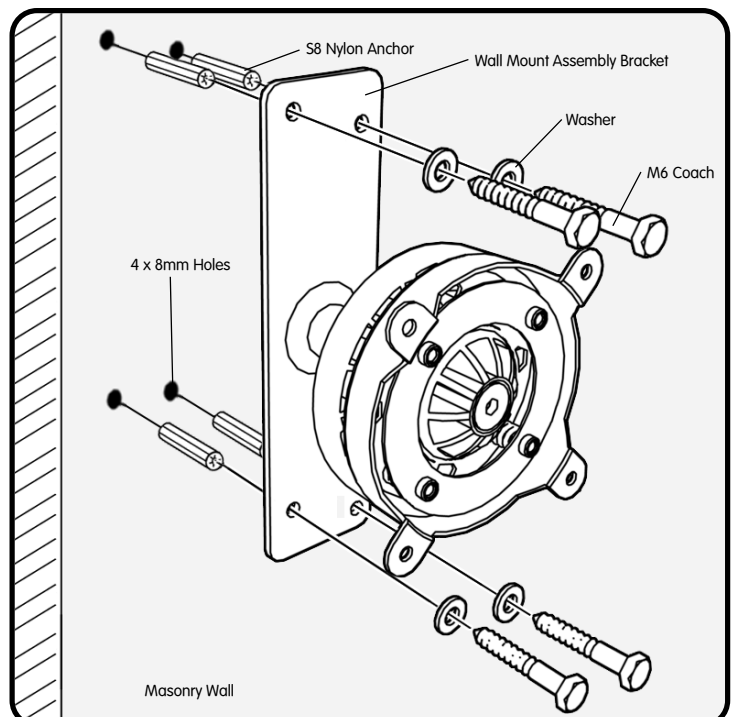

B.2.1.

## C VESA Screen Mounting Options

### C.1. Fitting A Monitor to the Wall Mount Assembly using the Direct Mount Configuration

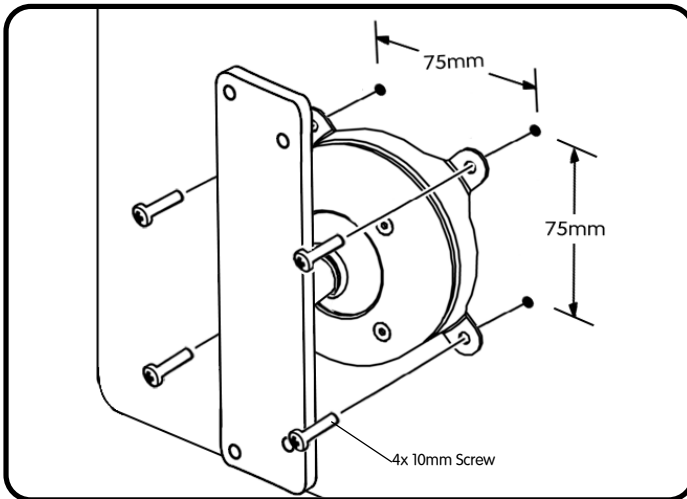

C.1.1. 75mm x 75mm hole arrangement

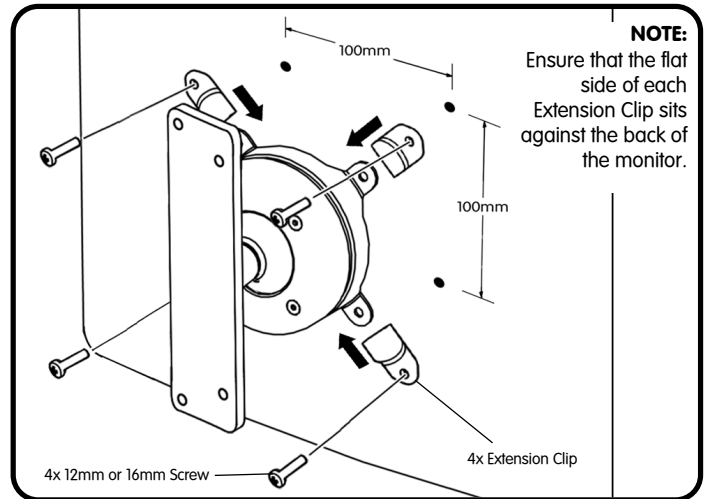

C.1.2. 100mm x 100mm hole arrangement

### C.2. Fitting A Monitor to The Wall mount Assembly with a Quick Release Mechanism (Optional)

**IMPORTANT: The key must be removed from the lock before the monitor is moved or rotated.**

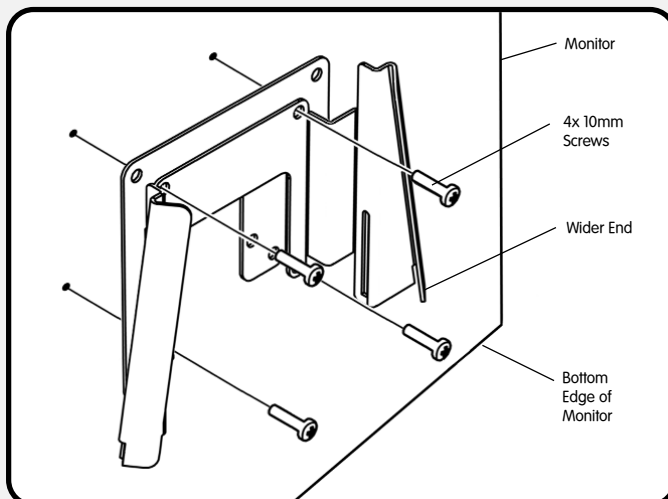

C.2.1. Ensure the wider end of the mounting plate faces towards the bottom edge of the monitor as shown in diagram C.2.1.

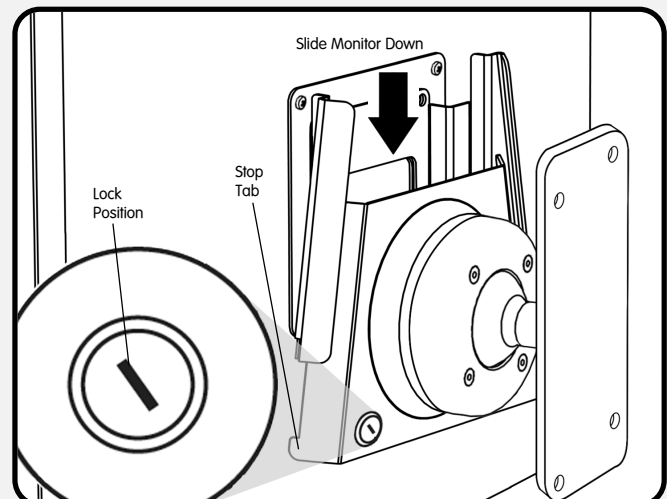

C.2.2. Once the monitor is pushed securely to the stop tabs lock the monitor in place with the Key as shown in diagram C.2.2.

## D Adjusting the Wall Mount Assembly for Tilt

**D.1.** Depending on the weight of the monitor, it may be necessary to make adjustments to the Ball Joint Mechanism. If the monitor doesn't hold its position or is too rigid, adjust the four tension screws located around the Ball Joint (see diagram D.1.1.). To make any adjustments, use the supplied 2.5 mm Allen Key to turn each screw one quarter (1/4) at a time.

**D.2.** Check the monitor, and then adjust again if necessary.

**Your bracket is now complete and ready to use.**

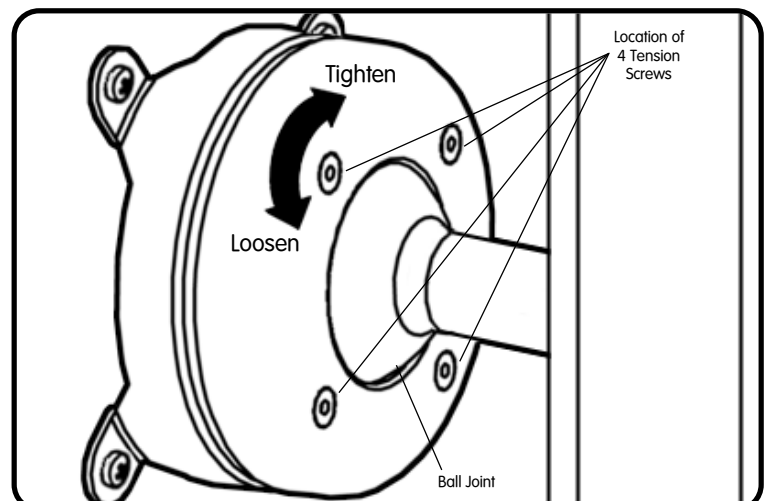

D.1.1.