



# FLUSH CEILING MOUNT ADAPTER FOR LCDA SERIES MOUNTS CMA-250

Unpack carton and check contents:

- (1) Ceiling Bracket
- (4) 1/4 - 20 x 1/2" Large Hex Head Bolt
- (4) 1/4" Lock Washer

### Installation Instructions:

1. See LCDA instructional view of top cross detail with threaded hole pattern.

2. Mate ceiling bracket to top cross using four 1/4 - 20 x 1/2" long bolts and lock washers. Insert them downward into the four threaded holes. **CAUTION! Ceiling bracket should be mounted perpendicular to assembly for ease when anchoring to the ceiling.** It can be mounted in either direction.

3. For flush mount applications and for better bolt head access, thread the two 1/4 - 20 x 1 1/4" long roll adjustment screws up from the bottom.

4. Determine projector orientation with regard to joist direction.

5. Secure LCDA assembly to structural joist using lag screws or comparable method. Insert through the two slotted holes in the bracket. Do slight adjustment prior to tightening.

### Adjustments:

Roll: Install two 1/4 - 20 x 1" bolts up from the bottom and turning one up and the other down to tilt the LCDA.

Yaw: Turn the assembly in the slotted hole prior to tightening.

Pitch: See LCDA Instructions.

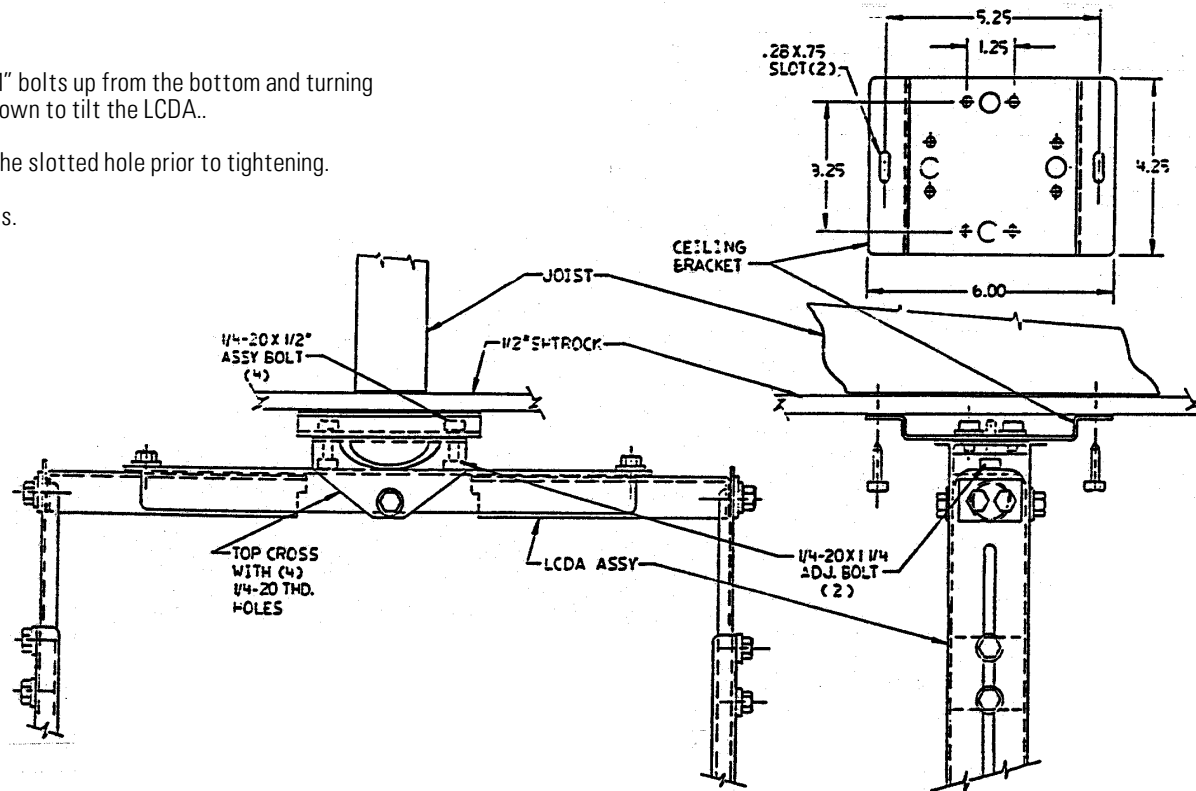

**WARNING: IMPROPER INSTALLATION MAY RESULT IN SERIOUS PERSONAL INJURY!**

The overhead support **must** be capable of supporting **five times** the weight of the mount **and** equipment combined. If it cannot, it **must** be reinforced.

