

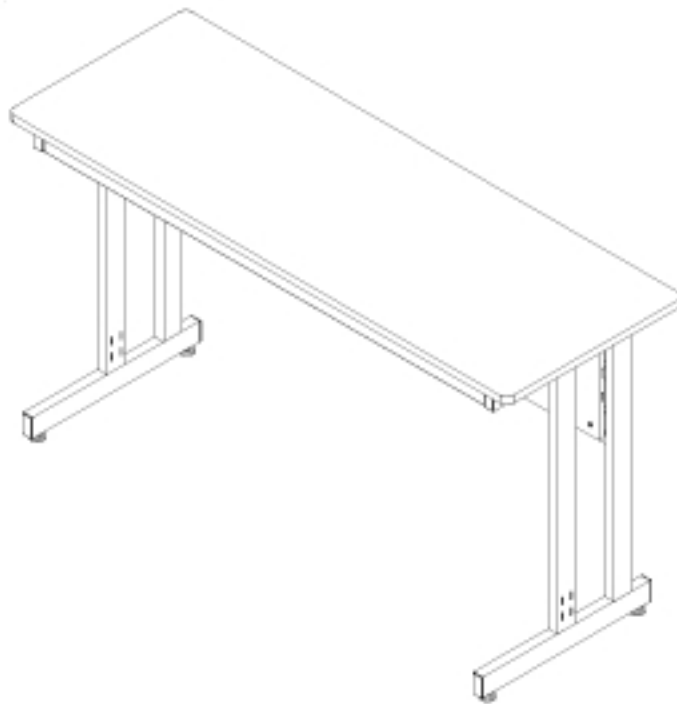

#89824 PJ Table





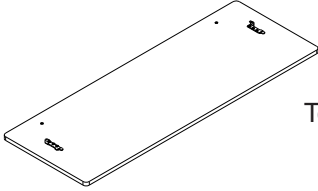
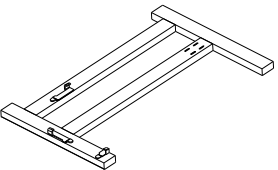
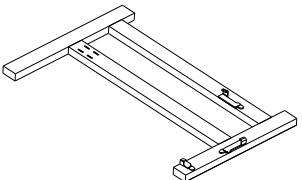
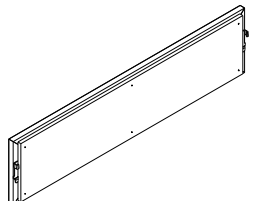
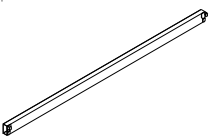

Assembly Instructions

#89824 PJ Table

Part#	Part Drawing	Description	Qty
P1		Top Platform	1 EA
P-2		Left Leg	1 EA
P-3		Right Leg	1 EA
P-4		Back Panel	1 EA
P-5		Front Crossbrace	1 EA

Hardware List

A		Thumb Screw M6 x 35mm	2 EA
B		2" Locking Caster	2 EA
C		2" Caster	2 EA
D		Leveling Glide	4 EA
E		Caster Wrench	1 EA

Missing Parts or UPS Damaged Parts

For Your Convenience you can
EMAIL us at

info@ergoindeman.com

24HOURS 7 DAYS A WEEK

*Should you require assistance
during assembly, please call our
Customer Service Department
Monday - Friday 7 a.m. - 4:30 p.m.*

*Pacific Standard Time
Toll-Free Customer Service*

1-800-888-6024

#89824 PJ Table

Assembly Diagram

Illustration # 1

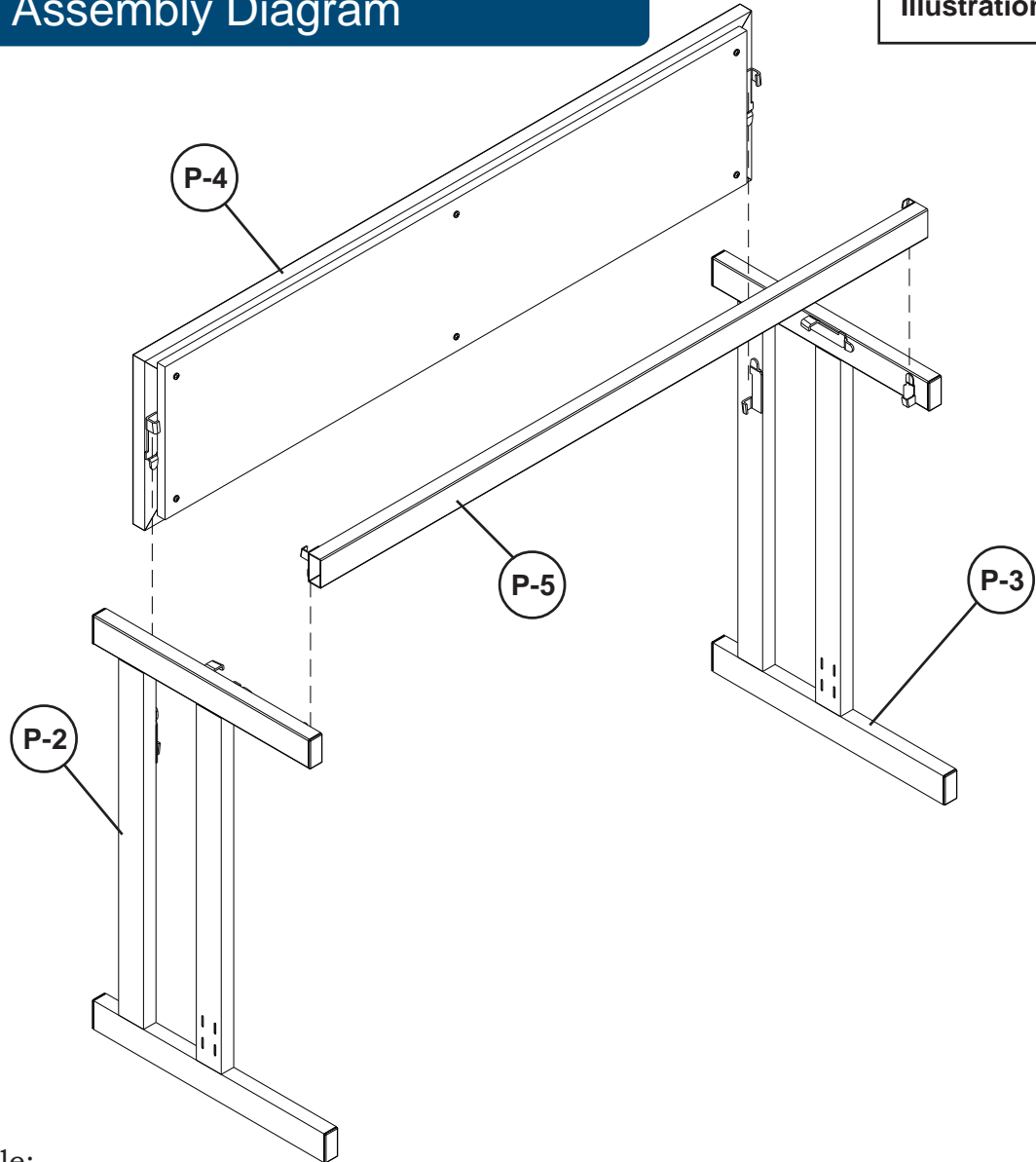

To Assemble:

1. Identify and Separate all the Parts and Hardware.
2. Place the Left Leg (P-2) and Right Leg (P-3) with the Metal Brackets facing each other. as shown in illustration # 1.
3. Slide Back Panel (P-4) into brackets on Left Leg (P-2) and Right Leg (P-3).
4. Slide Front Crossbrace (P-5) into brackets on Left Leg (P-2) and Right Leg (P-3) as shown in illustration # 1.

Do not use unless all screws are tight. At least every six months, check all screws to be sure they are tight. If parts are missing, broken, damaged, or worn, stop use of the product until repairs are made by your dealer using factory authorized parts.

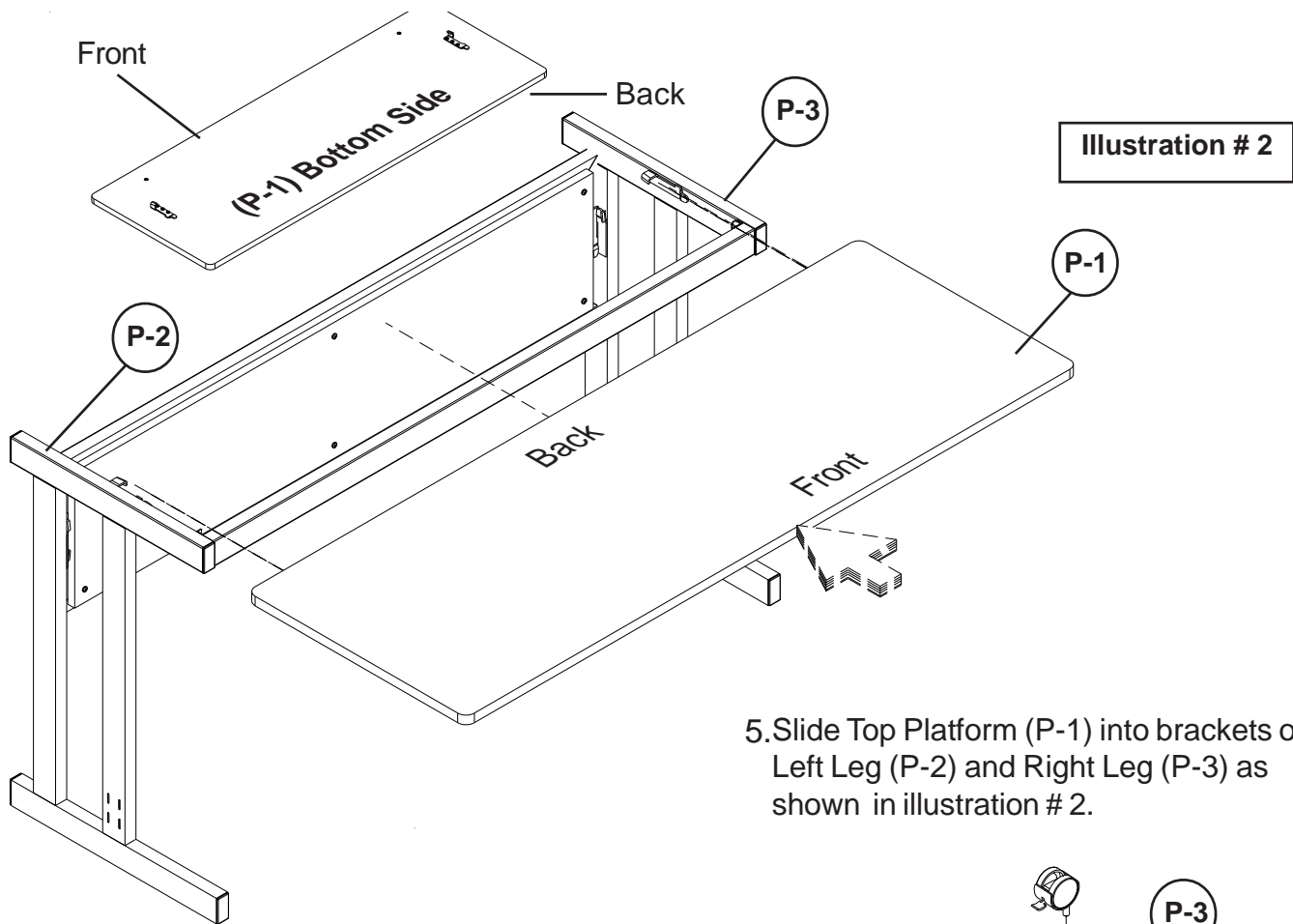

5. Slide Top Platform (P-1) into brackets on Left Leg (P-2) and Right Leg (P-3) as shown in illustration # 2.

6. Secure Top Platform (P-1) to the 2 Legs (P2&P3) using 2 Thumbscrews (A) as shown in illustration #3.

7. Attach 2 each Locking Casters (B) to the front of the 2 Legs (P2&P3) and 2 each Casters (C) to the back of the 2 each Legs (P2&P3).

8. Tighten Casters using Caster Wrench (E).

9. Use 4 each Leveling Glides (D) in place of Casters for stationary use.

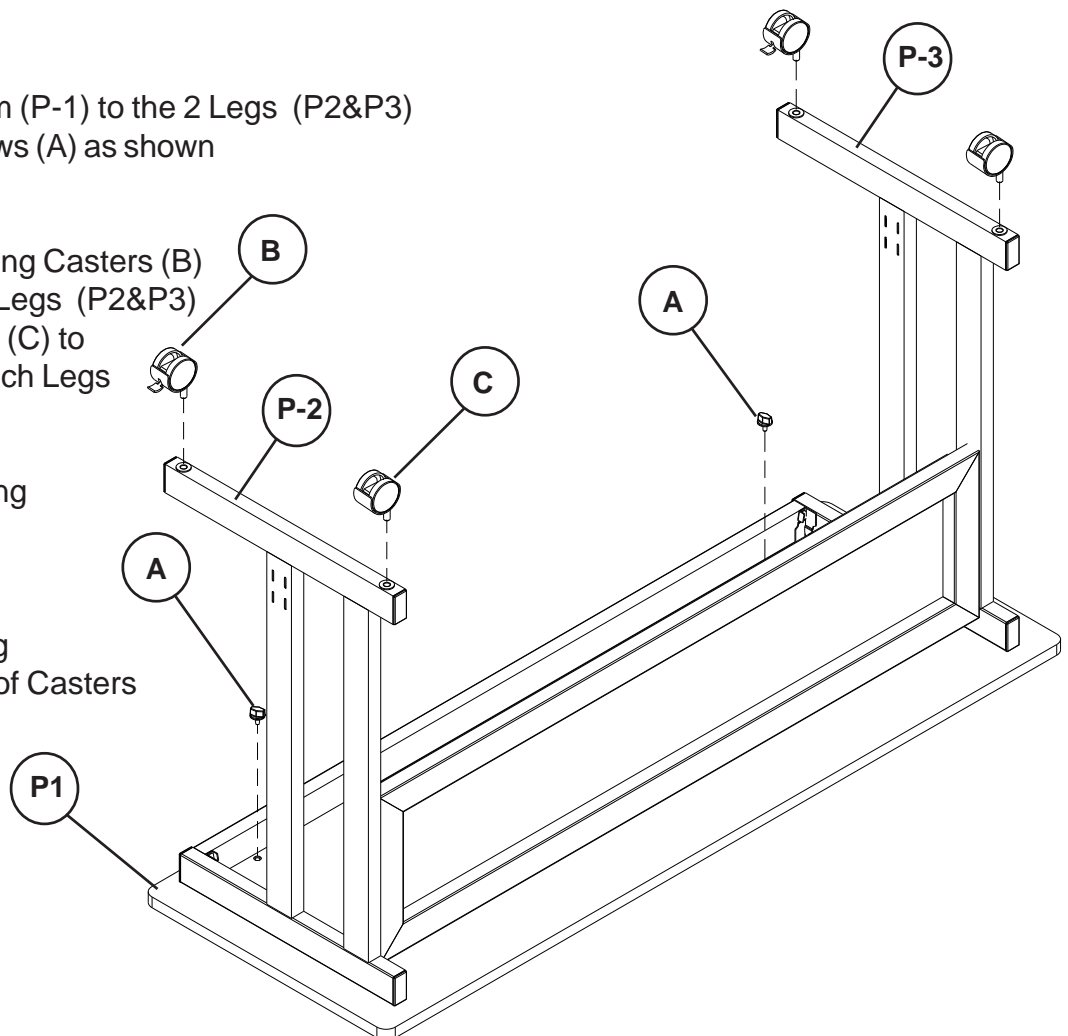

Illustration # 3